

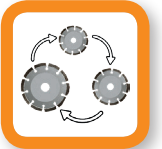

Ein Sägeblatt
Single blade



Versch. Durchmesser
Various diameters



Gehungsschnitte
Mitre cut



Schrägschnitte
Bevel cut

G8R

ABLÄNGSÄGE MIT SCHWENKBRÜCKE UND DREHTISCH
SWIVEL CROSS CUTTING MACHINE WITH TILTING HEAD



ABLÄNGSÄGE MIT SCHWENKBRÜCKE UND DREHTISCH SWIVEL CROSS CUTTING MACHINE WITH TILTING HEAD

G8R



Die Ablängsäge Modell **G8R** von DONATONI führt mit dem **DONATONI System X** einfach und präzise Abläng-, Gehrungs- und Fasenschnitte an Marmor-, Granit-, Keramik- und Quarzstreifen durch. Der drehbare Tisch ermöglicht in Kombination mit der Schwenkbrücke das Schneiden verschiedener Formen zur Erweiterung der Produktpalette.

- Einzelrollentisch
- Kraftübertragung über Riementrieb
- Anzeige des Drehwinkels des Tisches
- Anzeige des Schwenkwinkels der Brücke
- Geschnitten wird immer in der gleichen Nut auf der festen Tischplatte



Simple and precise, DONATONI model **G8R** cross cutting machine carries out cross, mitre and bevel cuts on both marble, granite, ceramics and quartzite strips thanks to **DONATONI System X**. The swivel table and the tilting head allow multiple shapes to be cut, widening the range of products that can be obtained.

- Idle roller table
- Belt-driven power transmission
- Display showing degrees of rotation of the table
- Display showing degrees of rotation of the bridge
- Cut always in the same groove on the fixed top of the table

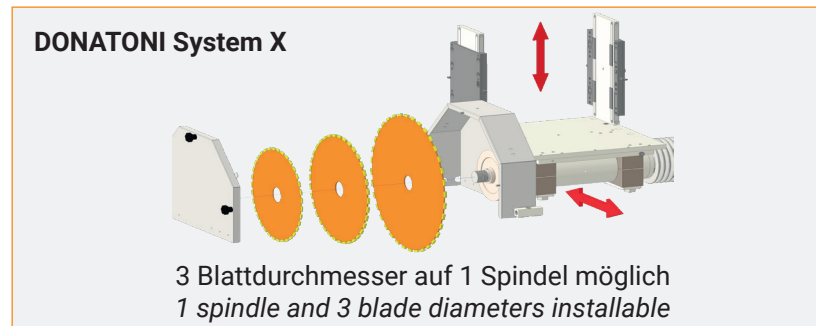
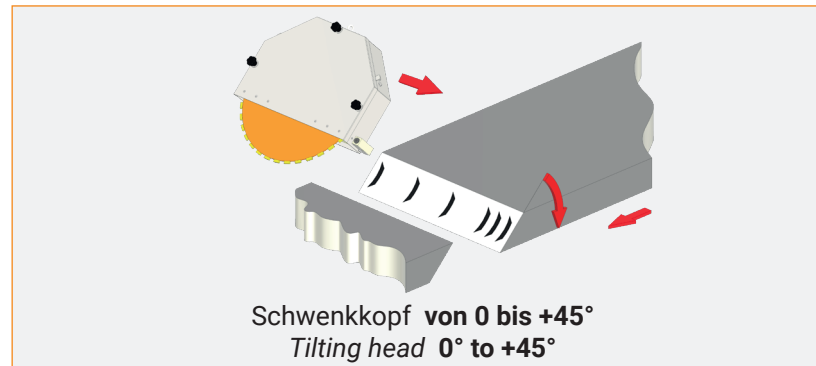
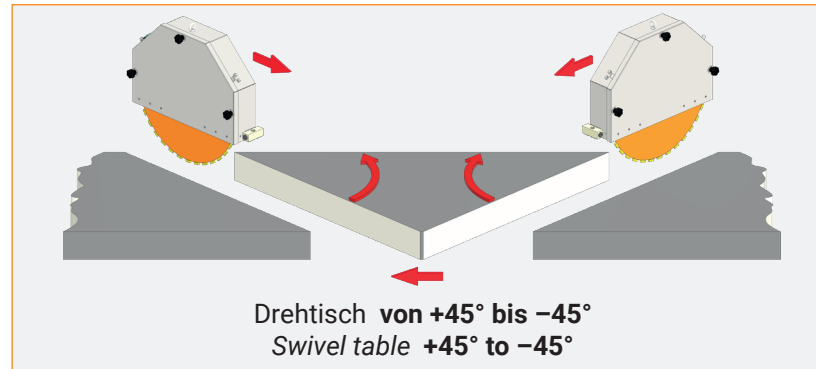

MODELL/MODEL	G8R
Effektive Schnittbreite Useful cutting width	850 mm (table 0°) 610 mm (table ±45°)
Maximale Materialstärke Maximum cutting thickness	100 mm (head 0°) 75 mm (head +45°)
Blattdurchmesser Suitable blade diameter	300-350-400 mm
Tisch Type of table	Einzelrollen Idle rollers
Tischdrehung in 1-Grad- Schritten Rotation of table at 1 degree intervals	-45° ... +45°
Schwenkung der Sägebrücke Spindle carrying bridge rotation	0° ... +45°
Installierte Leistung Blade spindle motor power	7,5 kW
Installierte Leistung Installed power	9,5 kW
Wasserverbrauch Water consumption	20 L/min
Druckluftverbrauch Air consumption	15 L/min
Abmessungen Overall dimensions	2850x3000x2300/h mm
Gewicht Weight	1850 kg



- Info
- Sales
- Service

Costruzioni Meccaniche Donatoni

Loc. Montean, 9 - 37010 Cavaion V.se (VR) Italia
Tel. +39 045 6260275 - info@donatoni.com

donatoni.com

